

From Eye to Insight



For anterior and posterior segment surgeries

EFFICIENCY YOU CAN FEEL,
PRECISION YOU CAN TRUST

Proveo 8 Ophthalmic
Surgical Microscope



Now available with optimized
EnFocus intraoperative OCT*

*Compared to the previous generation of EnFocus intraoperative OCT for Proveo 8

“With the Proveo 8 I am less distracted during surgery. The FusionOptics technology provides me a greater depth of field, and I don’t have to refocus the microscope so frequently”

Dr. Dornelles, M.D. Cataract Surgery Preceptor at Porto Alegre’s Eye Bank Hospital, Clinica Visao, Porto Alegre, Brazil



EFFICIENCY YOU CAN FEEL, PRECISION YOU CAN TRUST

Proveo 8 ophthalmic microscope



Efficiency

- > Personalized settings to support precise surgical actions and uninterrupted workflow
- > Individual procedures for each user and surgery type with CombinationMode
- > Intuitive microscope operation, large reach and ergonomic accessories

See pages 4 to 5

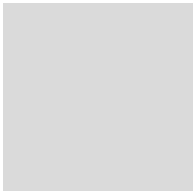
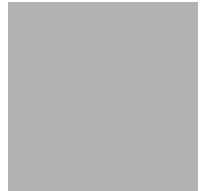

Visualization

- > Stable red reflex with CoAx 4 coaxial LED illumination
- > Low light, high contrast with adjustable field of illumination via footswitch
- > Superb texture and high depth of field with FusionOptics
- > Same view for surgeon, assistant, and camera

See pages 6 to 7



Flexibility

- > Accessories for individual needs in anterior and posterior segment surgery
- > Microscope benefits for anterior and posterior segment surgeries

See pages 8 to 9

Upgradeability

- > Enhance Proveo 8 at any time with EnFocus intraoperative Optical Coherence Tomography (OCT)
- > Configure according to your imaging and documentation needs
- > Proveo 8 configurations: floor stand and ceiling mount

See pages 10-12



EFFICIENCY YOU CAN FEEL

Work interruption-free with the Proveo 8 ophthalmic microscope.

With a Proveo 8 microscope you will experience the real meaning of workflow when each step of surgery connects smoothly with the next. Like a precision timepiece, every element of the Proveo 8 microscope interconnects and works in perfect synchrony, so you have the view you need, the moment you need it.



Supporting you step by step through your procedure

Typical ophthalmic surgeries are divided into phases, each requiring specific levels of light, focus, and magnification. With CombinationMode you can pre-define and program the settings you need for each phase of both anterior and posterior procedures.

During surgery, simply tap the assigned footswitch button to activate the settings for the next phase and continue working without interruption.

- > Program up to 5 phases, i.e. for cataract surgery: capsulorhexis, phacoemulsification, irrigation/aspiration, and posterior capsule polishing
- > Choose between 7 different parameters
- > Save individual settings for up to 30 surgeons
- > All OCT functions can be programmed to the footswitch for convenient intraoperative use



Select Quick Focus to immediately switch between two different focal planes and Quick Tilt for workflow efficiency in glaucoma procedures

EnFocus intraoperative Optical Coherence Tomography (OCT) system fully built into the stand

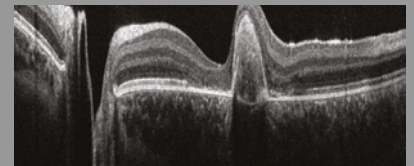

EnFocus OCT Integration for a smooth and independent workflow

Easily switch views to supplement your microscope view with bright, sharp OCT images to see subsurface tissue details. With a simple tap on the footswitch, the handle or even via touchscreen you can switch views during any point in your surgery.

EnFocus OCT is fully interconnected with the Proveo 8, so you can optimize your workflow by adding OCT settings to your personal Proveo 8 settings.

Large overhead reach of 1086 mm

A range of monitors available including a 27" touch screen



Control recording with only a touch of the infrared remote control, touchscreen control panel, or footswitch

NEW! Optimized EnFocus OCT scan head design with reduced height.*

Pre-assign handle functions according to the preferences of each user for fast, smooth adjustment

*Compared to the previous generation of EnFocus intraoperative OCT for Proveo 8

Very small footprint of 680 mm x 680 mm

Simple to start, fast to finish

Save precious time between surgeries for yourself and your OR team, with easy preparation and fast transition. The intuitive touch-screen control unit makes the microscope and OCT set-up easy. At the end of the surgery simply move the swing arm and all microscope functions automatically reset and the recorder even stops. The microscope is immediately ready for the next case.

Smooth, comfortable working

Pre-program the wireless footswitch with key microscope and intraoperative OCT functions, and maintain your surgical workflow in a comfortable posture. Switch functions with just a tap of the foot. Functions available include vitreoretinal (VR) mode, OCT control, tilting position, quick focus, and diameter of red reflex illumination. Position the footswitch exactly where you need it thanks to the lightweight, cable-free design.

Ergonomic means efficient

During surgery, your physical well-being can influence your concentration and efficiency. Choose from a large selection of binoculars and three different objective lens types to meet your individual physical requirements and those of your assistant. The large overhead reach of the Proveo 8 provides positioning freedom in the OR and supports ergonomically.

IMAGES YOU CAN TRUST



FusionOptics technology

1. Two separate optical beam paths
2. One beam path provides depth of field
3. The other provides high resolution
4. The brain merges the two images into a single, optimal spatial image

Seeing every fine detail at every moment is the basis for achieving the best patient outcome.

The Proveo 8 ophthalmic microscope goes beyond conventional visualization. Its exclusive optical technology provides you with both constant red reflex and a rich texture view, throughout entire anterior and posterior procedures.

FusionOptics

Technology

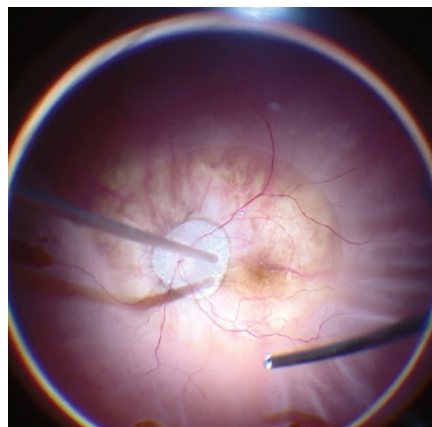

A texture-rich view

In posterior segment surgery, you need to carry out extremely precise work, often in low light conditions. Until now, this meant time-consuming refocusing, and limitations in image clarity and detail. Innovative FusionOptics is an exclusive technology from Leica Microsystems that delivers crisp, texture-rich images from the periphery to the retina.

FusionOptics captures different information from each of the two beam paths, delivering high resolution to the left eye and depth of field to the right eye. The brain easily merges the visual information into a high-contrast, detailed image with an expanded area in focus. Not only does this enhance your view, it enhances your workflow as refocusing is reduced.

“One of the benefits of Proveo 8 is the way the illumination is achieved by four coaxial LED lights. When this is combined with the optics of the microscope and the innovative extra depth of focus, it enhances our ability to visualize the procedure throughout the entire case.” Dr. Ike Ahmed, University of Toronto, Canada

Rely on consistent red reflex: CoAx 4 illumination

Concentrate on your cataract surgery and rely on consistent, brilliant red reflex and optimal image contrast throughout the entire procedure with exclusive CoAx 4 coaxial LED illumination. CoAx 4 illumination uses four individual beam paths from two LED lamps. The beam paths all enter the eye at perpendicular angles to the retina which results in a stable red reflex for all observers throughout all steps of cataract surgery. The illumination diameter is adjustable from 4 to 23 mm allowing for optimal alignment of the illumination to each individual patient's eye. This means lower light can be used while still achieving maximum contrast. Even if the eye moves intra-operatively, it remains in the field of illumination.

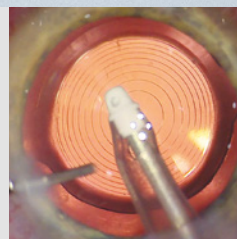
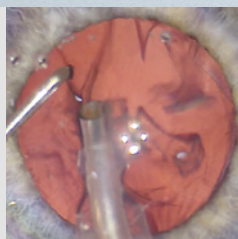
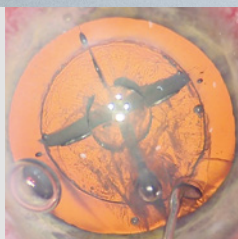
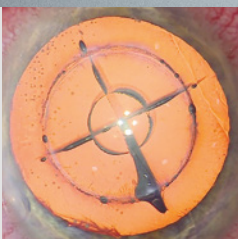
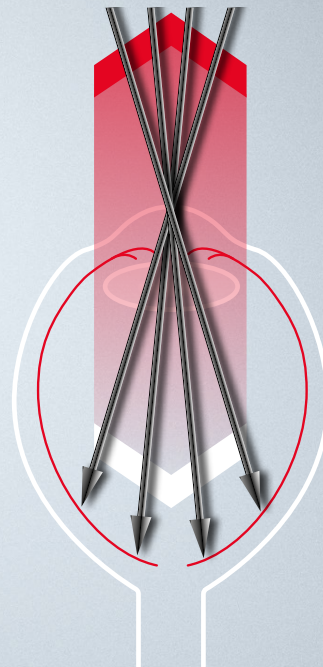

Consistent red reflex during the entire cataract procedure

See more
with less light



Featuring a high degree of light transmission, the Optichrome technology of Proveo 8 allows for low light while still delivering high contrast, high resolution and natural colors. Two LED lamps provide direct illumination with a consistent color temperature, light intensity and homogeneity over the complete life cycle of the microscope.

Share the benefits
with your team



Proveo 8 makes the red reflex fully visible for all observers. CoAx 4 Illumination includes a linked zoom system, which provides the same uncompromised view to main surgeon, assistant, and video camera.

A shared view of the surgical field with excellent contrast, consistent red reflex, same magnification and 100% stereo vision, enhances teaching and collaboration in the OR.

DESIGNED FOR YOUR NEEDS IN ANTERIOR & POSTERIOR SEGMENT SURGERIES

Surgeon Information Panel

Confirm your light, magnification, recording, focus level & mode settings, at one glance - right above the optics carrier.

Assistant fine focus

Benefit from the integrated assistant binocular tube with equal optical performance as main surgeon and camera.

Adjustable illumination diameter

Adjust red reflex illumination diameter with the knob or via the wireless footswitch.

Built-in keratoscope

Activate via footswitch to qualitatively evaluate the corneal curvature of the eye for astigmatism.



Benefits for Anterior Surgery

As an anterior surgeon you rely on red reflex as it provides ideal contrast to visualize the posterior capsule, lens and anterior chamber structure. CoAx 4 LED illumination by Leica Microsystems then takes your visualization to the next level: It provides consistent red reflex throughout the entire procedure, including phacoemulsification.

Proveo 8 is equipped with additional imaging technologies, such as built-in EnFocus OCT. It allows real-time, intraoperative confirmation of how tissue reacts to surgical maneuvers:

- > Confirming the absence of interfacial fluid in DMEK & DSAEK surgery
- > Checking the graft orientation during DMEK & DSAEK surgery
- > Measuring how deep to cut the corneal stroma in DALK surgery
- > Shunt Vessel placement and assessment in glaucoma surgery

Find out more on the next page.

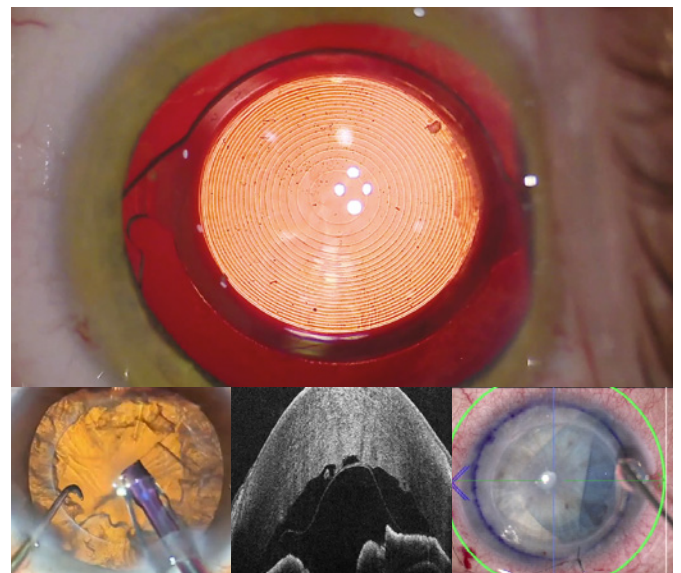



Choose your ideal position
Change the assistant binoculars from left to right in seconds according to the surgery set-up.

HD Medical Camera HD C100
Display and capture your procedure in brilliant high definition quality videos or pictures.

Integrated inverters for the IVC configuration*
Automatically activated and synchronized when VR mode is selected (main surgeon & assistant).

Fine focus for camera

Integrated slit illumination
Motorized internal slit illumination allows continuous adjustment of slit width from 2 - 6 mm and slit direction from right to left. Not activated with fully built-in EnFocus OCT in Proveo 8.

EnFocus intraoperative OCT with optimized design
Greater insights into subsurface details for immediate confirmation of tissue reaction to surgical maneuvers.

Accessories for posterior Surgery



External slit illumination
Adjustable slit beam path in width and length. Scan over the cornea from any position via the foot switch (not available with EnFocus OCT).

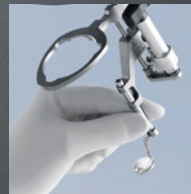

BIOM 5 with synchronized focus
For contact-free, wide-angle observation of the fundus during vitreous surgery.



RUV800 retinal wide-angle viewing system
The integrated inverter provides an upright view of the retina to surgeon, assistant and camera (not available with EnFocus OCT).

*Picture shows the Proveo 8 IVA configuration (integrated video adapter) for the use of the external Leica medical camera HD C100. The IVC configuration (integrated video camera) features the built-in Leica 3CMOS camera HD C300.

Benefits for Posterior Surgery

When performing posterior surgery you need to clearly see through the vitreous to every structure of the retina, without frequent refocusing. FusionOptics technology overcomes the boundaries of sight by uniting high resolution and depth of field for a crisp texture-rich view of fine details. A full selection of wide-angle viewing systems further supports your visualization and workflow during vitreoretinal surgery.

Predefined modes and OCT imaging for posterior surgery

Use the pre-programmed settings for vitreoretinal procedures and even supplement them with OCT imaging. With a simple tap on the footswitch the microscope adjusts automatically. Fully built-in OCT allows you to easily acquire high resolution OCT scans, which you can record and review carefully during surgery to overcome uncertainties in complex for example in retinal detachment cases or macular hole repair.

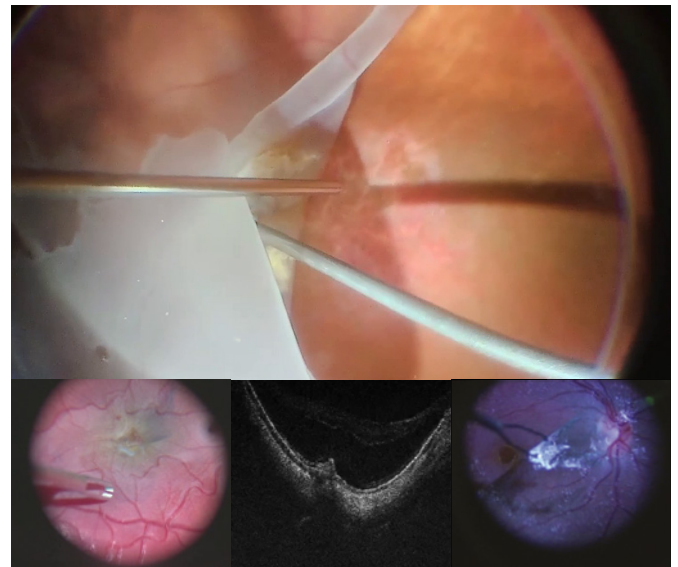

FOCUS ON PERFECTION

Apply your skills with even greater confidence during surgery with EnFocus intraoperative OCT built into the Proveo 8 ophthalmic microscope.

Intraoperative OCT allows you to see what lies underneath the surface, giving you additional information for a complete understanding of how subsurface tissue reacts to your surgical maneuvers in real-time. At any step during surgery you can simply enhance your microscope view and add intraoperative OCT imaging with just a few taps. You get an immediate visual confirmation on ocular tissue behaviour so you can focus on achieving an optimal patient outcome. Choose Proveo 8 with EnFocus already built in or upgrade at any time.

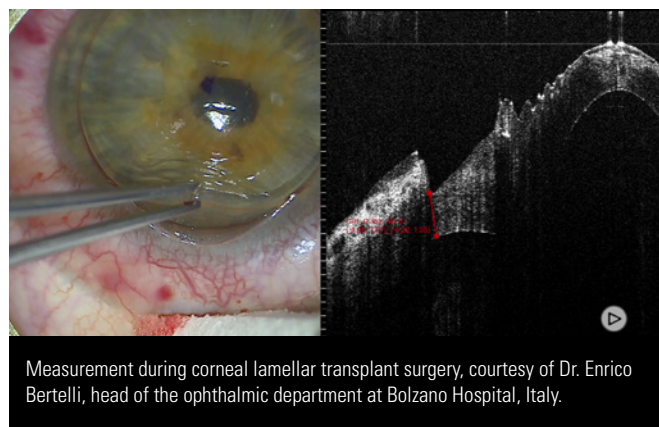
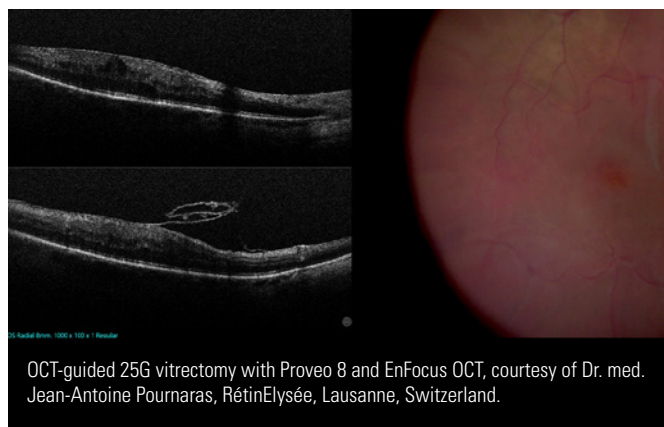

Greater insights

Supplement your microscope view with bright, sharp imaging of previously hidden subsurface details to better understand ocular pathology.

- > Clearly differentiate between artifacts and tissue due to the unique spectrometer technology including dispersion compensation software and a highly sensitive detector that captures more signal
- > See fine details with an axial resolution of 4 μm in tissue due to the patented Leica spectrometer design
- > Capture comprehensive area scans with high lateral resolution, due to a high scan density of up to 1000 A-scans x 1000 B-scans
- > See the full surgical field from the center to the periphery at all magnification levels thanks to a 20 x 20 mm lateral field of view
- > Obtain a complete image of the anterior chamber thanks to the increased scan depth of 5 mm in total*

Immediate confirmation

Confirm in real-time how ocular tissue is reacting intraoperatively to your surgical maneuvers. Adjust your plan as needed for greater confidence in the surgical outcome.

- > Real-time display of 30 fps provides immediate feedback at each step e.g. to verify adherence of donor tissue in DMEK or DSAEK surgery
- > If OCT reveals a complication which wasn't visible via the microscope view, for example due to bleeding, you can instantly adapt your surgical plan
- > For additional confirmation you can easily review or playback through the acquired scans frame by frame or in playback video mode
- > On-screen live measurements provide additional confirmation e.g. cornea thickness and needle depth during DALK surgeries

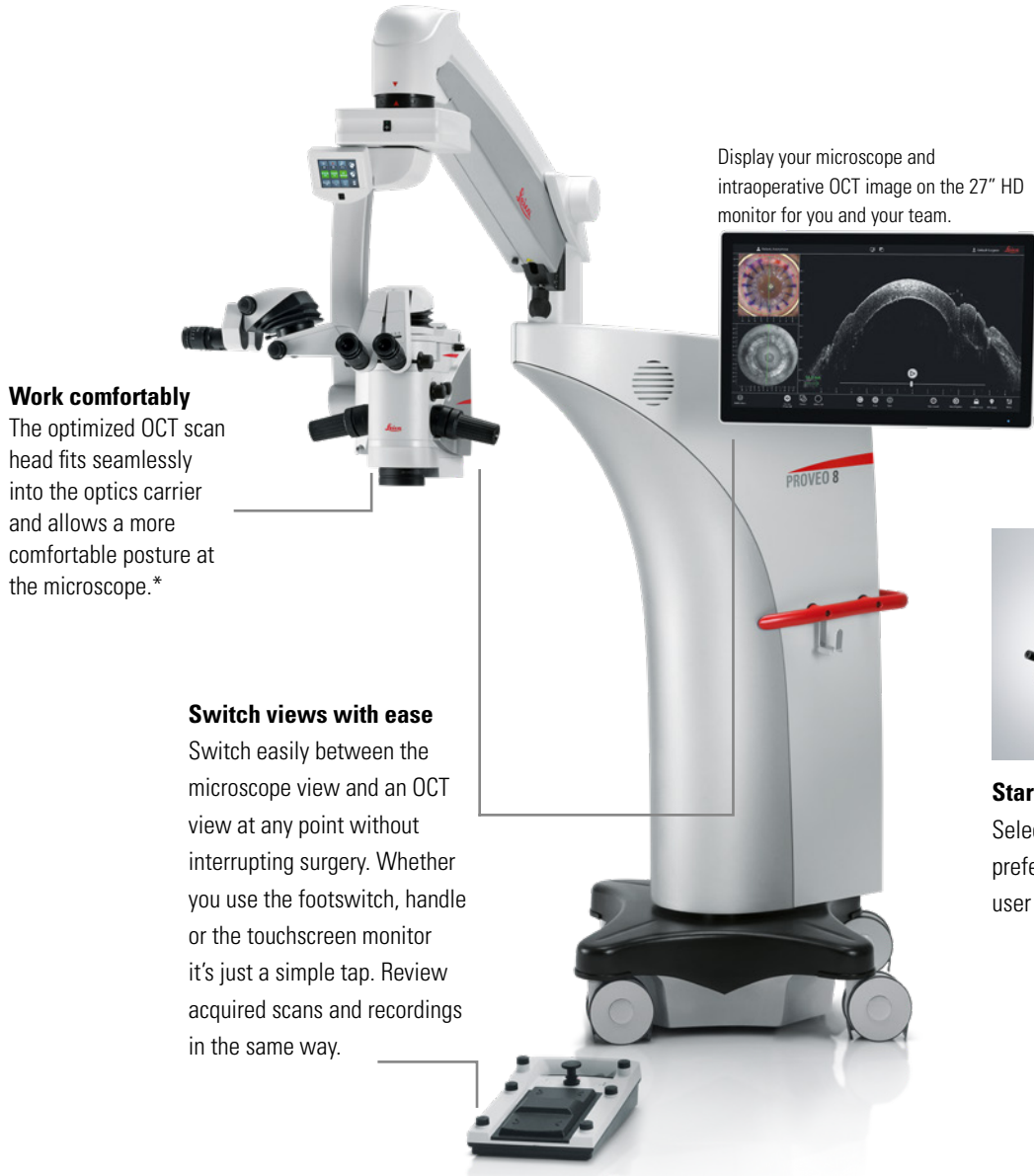

Work comfortably

The optimized OCT scan head fits seamlessly into the optics carrier and allows a more comfortable posture at the microscope.*

Switch views with ease

Switch easily between the microscope view and an OCT view at any point without interrupting surgery. Whether you use the footswitch, handle or the touchscreen monitor it's just a simple tap. Review acquired scans and recordings in the same way.

Display your microscope and intraoperative OCT image on the 27" HD monitor for you and your team.



Touch screen control

Multi-touch gesture control can be used by you or your assistant during surgery to adjust for example the scan position in the z-axis, the image size and rotation. Also you can activate the recording and replay.

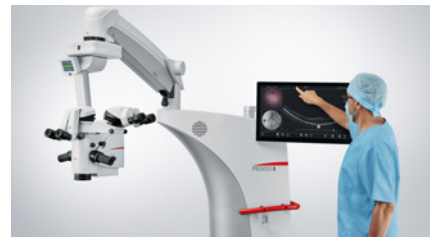

Start surgery quickly

Select, modify, and load the surgeon preferences using the intuitive touch screen user interface.



“Having confirmation at every step during surgery is a huge advantage and helps enormously in surgical decision-making and diagnosis. In my experience intraoperative OCT makes the difference between compromise and perfection.”

Dr. Barbara Parolini, Eyecare Clinic Brescia, Italy.

Maximum freedom

OCT can now be fully integrated into your Proveo 8 and into your workflow. Switch views and record effortlessly with the assurance that you will always have consistent, optimized OCT imaging available when you need it.

- > For an uninterrupted workflow, your personal settings and modes can be pre-programmed into the footswitch and handle control, according to surgery type and workflow step
- > Preferences such as scan sizes, scan pattern, and scan density are fully customizable to your requirements
- > Auto-locate, auto-brighten, and auto-sharpness functions enable you to further optimize the image if needed, with just one tap of footswitch, handle or screen
- > Location Lock in z-direction keeps the OCT image centered automatically, no need for manual intervention
- > Work in a more relaxed posture thanks to the optimized EnFocus OCT scan head design with reduced stack height*

*Compared to the previous generation of EnFocus intraoperative OCT for Proveo 8

CONFIGURE ACCORDING TO YOUR NEEDS

Anterior and posterior surgery, spacious OR or small & crowded, Proveo 8 responds to your needs.



Easy positioning, wherever, whenever - your Proveo 8 comes in various configurations

With a compact footprint and long reach, the Proveo 8 floor stand offers you more space to work and the flexibility to smoothly position wherever is most convenient.

In a crowded or small OR, the Proveo 8 telescope mount frees up floor space and can be mounted on solid or suspended ceilings. The OCT module for the ceiling mount option comes on a cart, so you are free with the positioning.

Benefits of the Proveo 8 telescope mount CT42

- > The most compact option for a small or multifunctional OR
- > Can be adjusted to different ceiling heights
- > Quickly raise or lower via the included remote control



Simply select how you want to see or document your surgery - Proveo 8 offers various visualization and recording options

Proveo 8 is available with built-in 3CMOS, or external HD camera, all with easily accessible, independent fine focus. The microscope is compatible with 4K documentation systems. The additional C-mount adapter also allows the use of various 1/3" cameras.

The recommended documentation and recording systems for Proveo 8 with built-in EnFocus OCT is the Evolution4K recorder, offering:

- > 4K UHD & HD video/still image recording
- > Integrated 12.7 cm touch LCD screen
- > DICOM integration
- > One-touch recording

Proveo 8 has four video outputs, so you can route the image signal not only to the recording system, but also to external screens in your OR, for an enhanced visualization.

TECHNICAL DRAWINGS

F42 Floor Stand

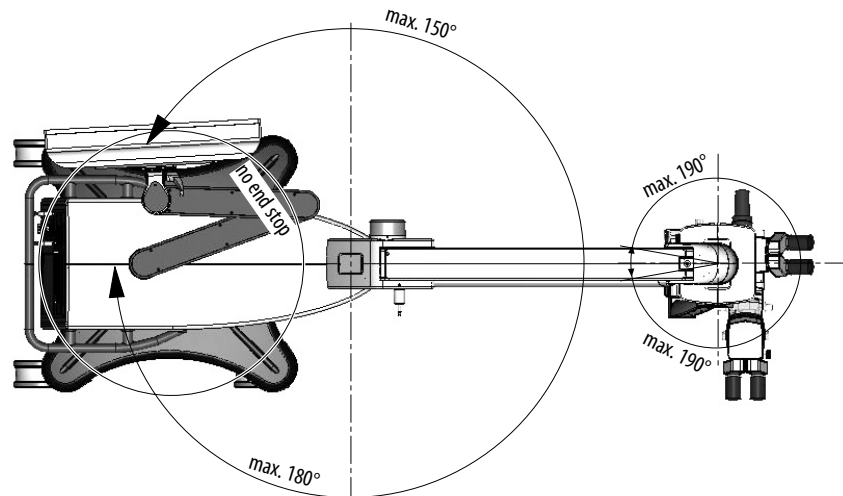
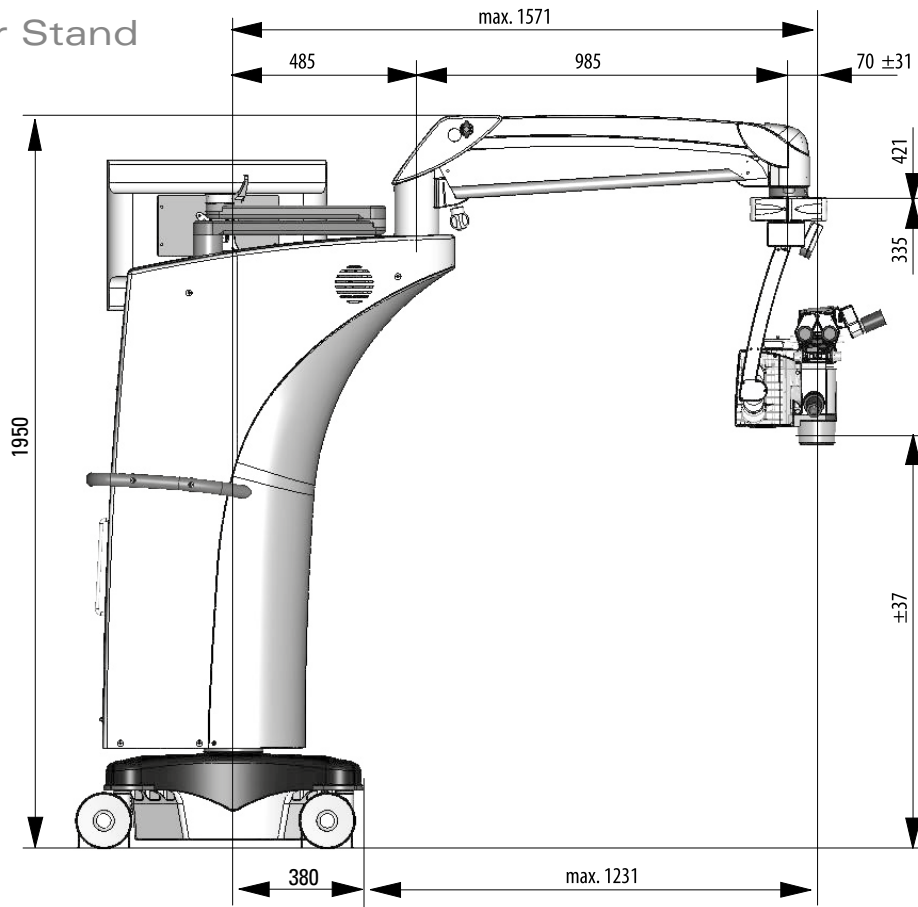

CT42 Telescope Mount

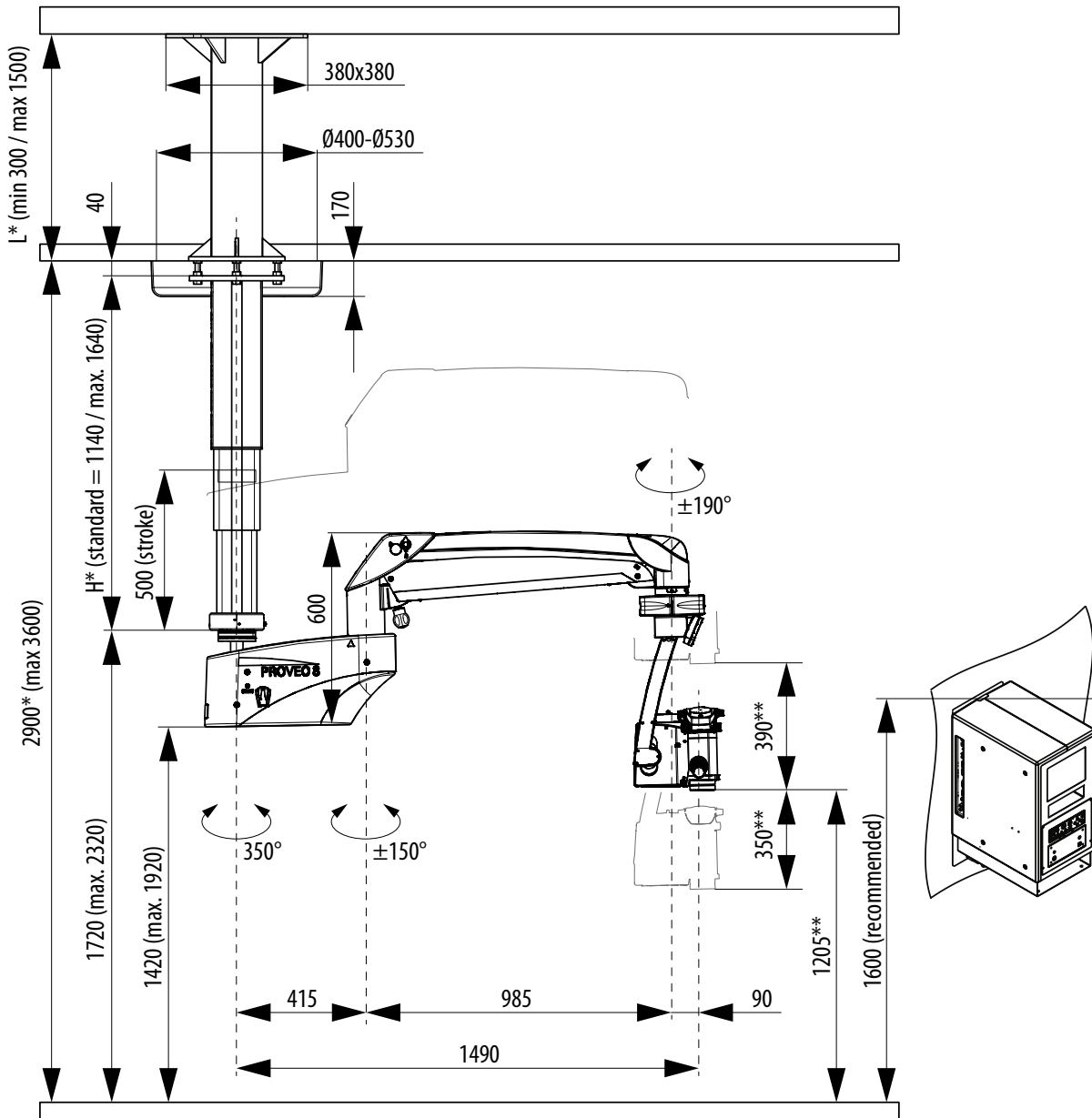

* variable, depending on OR height

**up/down movement of Parallelogram, w/o Tilt-Focus

TECHNICAL SPECIFICATIONS PROVEO 8

Construction

Floor stand	Four 360° rotating castors (Ø150 mm), parking brake
Materials	<ul style="list-style-type: none"> > Conforming with RoHS > Coated with antimicrobial paint
Load	<ul style="list-style-type: none"> > Floor stand max. 8.0 kg from microscope dovetail ring interface > CT42 max. 8.0 kg from dovetail ring interface
Weight	<ul style="list-style-type: none"> > Floor stand approx. 380 kg without load, without built-in EnFocus OCT > Floor stand approx. 390 kg with built-in EnFocus OCT > CT42 telescope mount total approx. 200 kg

Technical data

Power connection	<ul style="list-style-type: none"> > 600 VA 50/60 Hz > 100–240 V~ 50/60 Hz > 2 × T10 AH 250 V
Protection class	Class 1

Optics and Illumination

FusionOptics	For increased depth of field and high resolution for main surgeon and assistant
OptiChrome optics	For high contrast, high resolution, natural colors without chromatic aberrations
Magnification	6:1 zoom, motorized
Total magnification	4.1× to 24.5× with 10× eyepiece 5.1× to 30.7× with 12.5× eyepiece
Focus range	75 mm
Objective / working distance	WD 175 mm/f = 200 mm WD 200 mm/f = 225 mm WD 225 mm/f = 250 mm WD: Working distance, f: Focal length
Field of view	51.4–8.6 mm Ø with 10× eyepiece
Eyepieces	Wide-field eyepieces for persons wearing glasses 8.3×, 10× and 12.5× dioptic adjustment, ±5 diopter settings, adjustable eyecup
Direct illumination with 2 LED lamps	<p>Main light</p> <ul style="list-style-type: none"> > Integrated LED illumination system for intensive uniform illumination of the field of view > Continuously adjustable brightness with halogen-like color temperature

	CoAx 4 coaxial illumination
	<ul style="list-style-type: none"> > Illumination unit for generating a clear and stable Red Reflex, decreasing stray light through the sclera and increasing the image contrast
Adjustable CoAx 4	Diameter of coaxial illumination is adjustable between 4 and 23 mm via footswitch
Keratoscope	External adapter available for integrated Keratoscope illumination
Fine focus	Available for assistant and integrated camera or external 1/3 camera with C-mount interface
Fundus viewing systems	Compatible with BIOM 5, BIOM Ready, RUV800, and flat contact lens

Upgradeability

OpenArchitecture	Prepared for integration of video camera systems, digital recording and imaging systems such as EnFocus OCT and monitors
Connectors	<ul style="list-style-type: none"> > Four built-in video connectors for transfer of video and control data (DIV Out, DIV In, C-video Out, HD-SDI Out) > Internal power supply 12 VDC, 19 VDC, 24 VDC and AC terminals
2D Video	Optional fully integrated 2D HD video and recording

Maneuverability

Optics	<ul style="list-style-type: none"> > 380° rotation > -15° to +105° motorized inclination tilt
XY speed	Zoom linked XY speed
XY range	62 × 62 mm
Balancing	Adjustable gas spring via balancing knob
Brakes	Floor stand with 4 electromagnetic brakes
Monitor arm	860 mm flexible arm with 4 axis for rotation and inclination, max. weight 15 kg for 27" monitors

Proveo 8 Control

Control unit	<ul style="list-style-type: none"> > User-friendly, individually programmable touch-screen (up to 30 surgeons) for control of motor functions and light intensity > Menu selection based on unique software for user-specific configuration > Built-in electronic auto-diagnosis and user support > Software independent hard keys and indicator for illumination > Data shown by means of LCD
Control elements	<ul style="list-style-type: none"> > Rotary handles > 14-function and 12-function wireless footswitch with optional back-up cable
IR sensor	Remote control of the HDR recorder
Indicators	<ul style="list-style-type: none"> > LED for video record status > Surgeon information panel for setting status

EnFocus OCT Optical Performance

Axial resolution in tissue	4.0 μm
Lateral resolution	31 μm for 175 mm objective 35 μm for 200 mm objective
Imaging depth in tissue	5 mm +/- 0.1 mm
Lateral field of view (scan range)	up to 20 mm x 20 mm across entire range of microscope magnification
Image display resolution	1920 x 1080 pixels

Image acquisition speed	> 36000 scans/s, 30Hz B-scan display refresh rate
OCT optical power	< 750 μW
Imaging center wavelength	860 nm
175 mm objective lens working distance	178 mm
200 mm objective lens working distance	203 mm
OCT compatible fundus viewing systems	Compatible with BIOM 5, BIOM Ready, and flat contact lens

EnFocus OCT Physical Features

Workstation Operating System	64-bit, Windows 10
Removable scan head	Yes
OCT scanner dimensions	5.43 cm (h) x 11 cm (w) x 24.53 cm (l)
Scan head weight	1.3 kg (2.9 lbs)

EnFocus OCT Configurations

Proveo 8 floor stand	Built-in EnFocus OCT system with optimized scan head design
Proveo 8 with CT42 ceiling mount	External EnFocus OCT system unit on cart, standard scan head design*

*Technical specifications vary, ask your local Leica sales representative for information.

 Proveo 8 is a Class I surgical microscope

 Leica Microsystems (Schweiz) AG
Max Schmidheiny-Strasse 201
9435 Heerbrugg, Switzerland

 EnFocus OCT is a class IIa medical device

 Leica Microsystems NC, Inc.
4222 Emperor Blvd, Suite 390,
Durham, NC 27703, USA



Leica Microsystems CMS GmbH
Ernst-Leitz-Strasse 17-37
35578 Wetzlar, Germany

Not all products or services are approved or offered in every market. Approved labeling and instructions may vary between countries. Please contact your local Leica representative for details.



Leica Microsystems (Schweiz) AG · Max Schmidheiny Strasse 201 · 9435 Heerbrugg · Switzerland
T +41 71 726 3333 · F +41 71 726 3399

www.leica-microsystems.com

CONNECT WITH US!

